

## COAX® cartridge MICRO Bi03-2, holding cap

Article number: 0106968



- Two-stage COAX® cartridge - MICRO - probably the world's smallest multistage vacuum ejector.
- Vacuum level to 83 -kPa at extremely low feed pressure.
- High operational reliability in case of fluctuating or low compressed-air pressure.
- The low weight makes it suitable to integrate close to the suction point in high speed pick-and-place applications of small objects.
- Suitable for handling sealed objects.

### Technical data

Description	Unit	Value
Material	-	Al, Nitrile (NBR), PA, SS, TPE
Temperature, max.	°C	80
Temperature, min.	°C	-10
Weight, min.	g	7.9
Feed pressure, max.	MPa	0.7

### Performance

Feed pressure MPa	Air consumption Nl/s	Vacuum flow (Nl/s) at different vacuum levels (-kPa)													Max vacuum kPa		
		0	10	20	30	40	50	60	70	75	80	90	95	99			
0.11	0.1	0.17	0.1	0.04	0.027	0.013	0	0	0	0	0	0	0	0	0	0	≥50
0.18	0.14	0.23	0.15	0.06	0.04	0.035	0.023	0.013	0.006	0	0	0	0	0	0	0	≥83
0.22	0.17	0.27	0.19	0.09	0.04	0.025	0.02	0.01	0.005	0	0	0	0	0	0	0	≥82

Feed pressure MPa	Air consumption Nl/s	Evacuation time (s/l) to reach different vacuum levels (-kPa)														Max vacuum kPa	
		10	20	30	40	50	60	70	80	90	95	99	99.5	100.3			
0.11	0.1	0.7	2.9	5.9	11	28	0	0	0	0	0	0	0	0	0	0	≥50
0.18	0.14	0.5	1.4	3.9	6.4	10	16	28	51	0	0	0	0	0	0	0	≥83
0.22	0.17	0.4	1.1	3.3	6.4	11	18	32	62	0	0	0	0	0	0	0	≥82

## Dimensional drawings

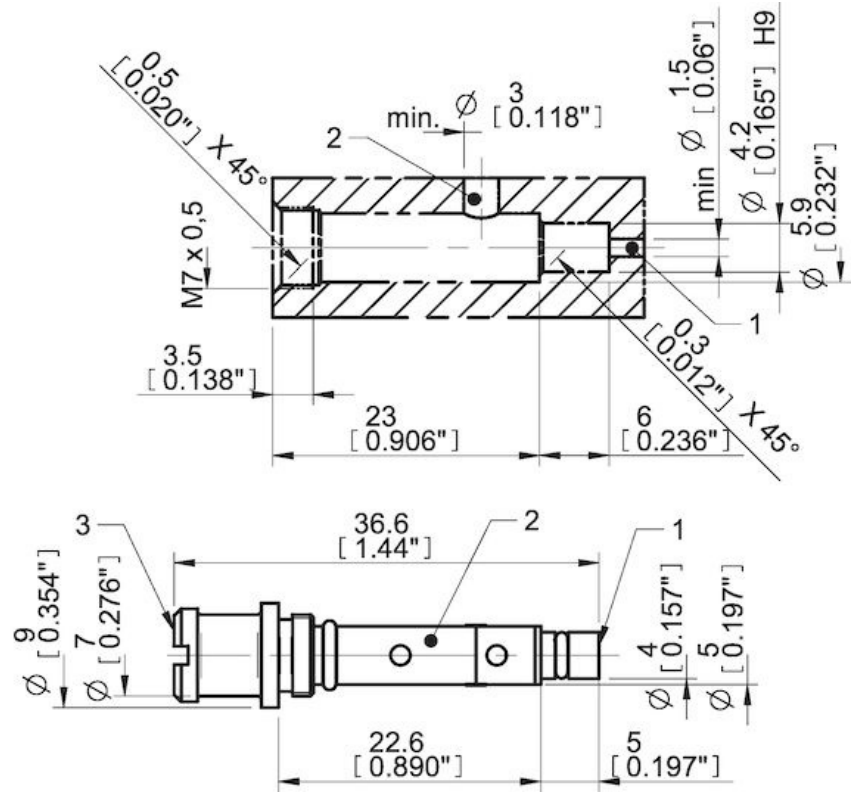
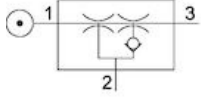

Values specified in this datasheet are tested at (unless otherwise stated):

- Room temperature (20°C [68°F]  $\pm$  3°C [5.5°F]).
- Standard atmosphere (101.3 [29.9 inHg]  $\pm$  1.0 kPa [0.3 inHg]).
- Compressed air quality, DIN ISO 8573-1 class 4.

Tolerance and accuracy:

- Feed pressure tolerance  $\pm$ 0.02 MPa [2.9 psi]
- Vacuum flow/evacuation time accuracy  $\pm$ 10%.