

Suction cup U2 Conductive silicone

Article number: 3150284SC

- Suitable for objects with flat or slightly curved surfaces.
- Also used for concave objects.
- Suction cups of conductive silicone are suitable for objects with sensitivity to static electricity.



Technical data

Description	Unit	Value
Suction cup shape	-	Universal
Application	-	Electronic / semiconductor
Suction cup design	-	Round
Characteristics	-	ESD/Conductive/Antistatic
Material	-	Silicone (SIL)
Weight, min.	g	0.012
Suction cup model	-	U
Volume	cm ³	0.003
Height	mm	3.5
Outer diameter, min.	mm	2.6
Fitting size	-	None
Fitting option	-	None
Fitting style	-	None
Fitting type	-	None
Suction cup model	-	U2
Movement, vertical max.	mm	0.1
Curve radius, min.	mm	4

Performance - Lifting forces

U2	Vertical (N)	Parallel (N)
20 -kPa	0.03	
60 -kPa	0.1	
90 -kPa	0.15	

Material	
Name	Conductive Silicone (CSIL)
Colour	Black
Temperature, min. °C	-55
Temperature max. °C	230
Hardness °Shore A	50

Material resistance

Alcohol	Good
Concentrated acids	Poor
Ethanol	n/a
Hydrolysis	Fair
Methanol	n/a
Oil	Poor
Oxidation	Excellent
Petrol	Poor
Wear resistance	Good
Weather and ozone	Excellent

Dimensional drawings

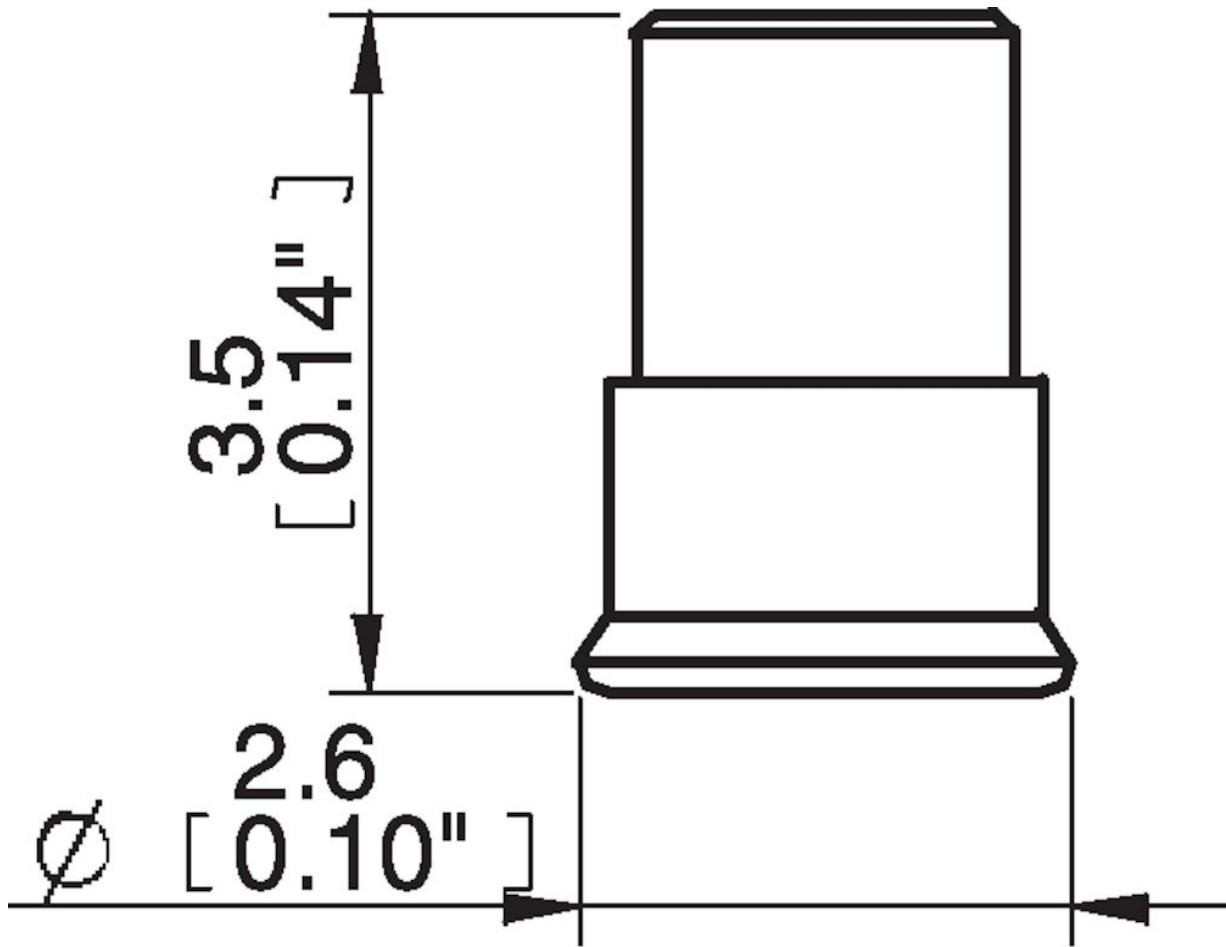

Values specified in this data sheet are tested at (unless otherwise stated):

- Room temperature (20°C [68°F] ± 3°C [5.5°F]).
- Standard atmosphere (101.3 [29.9 inHg] ± 1.0 kPa [0.3 inHg]).
- Relative humidity 20-70%.
- Compressed air quality, DIN ISO 8573-1 class 4.

Accessories

3250084 | Fitting M2.5 male