

## Suction cup F26 Silicone FCM

Article number: 0201216



- Designed for opening bags in bag filling stations.
- Also suitable to handle thin and sensitive sheets, such as paper and plastic films.
- The thin, conformable lip and clever cleat pattern prevent sensitive object/sheet to get sucked in and damaged while giving enhanced lifting force.
- FDA approved silicone material.

### Technical data

Description	Unit	Value
Suction cup shape	-	Flat
Application	-	Thin paper / slip sheets / film, Food contact materials (FDA & EU), non-detectable
Suction cup design	-	Round
Characteristics	-	Bag opening/thin paper - slip sheets/film, Food contact materials (FDA & EU), non-detectable
Material	-	Silicone (SIL)
Weight, min.	g	4.1
Suction cup model	-	F
Volume	cm <sup>3</sup>	1.6
Height	mm	23.5
Outer diameter, min.	mm	26
Outer diameter, actuated	mm	27.3
Fitting size	-	None
Fitting option	-	None
Fitting style	-	None
Fitting type	-	None
Suction cup model	-	F26 FDA
Movement, vertical max.	mm	1.5
Curve radius, min.	mm	25

### Performance - Lifting forces

F26 FDA	Vertical (N)	Parallel (N)
20 -kPa	11	9
60 -kPa	25	21
90 -kPa	31	26

Material	
Name	Silicone (SIL FDA) 50° Shore
Colour	Blue
Temperature, min.   °C	-40
Temperature max.   °C	200
Hardness   °Shore A	50

### Material resistance

Alcohol	Good
Concentrated acids	Poor
Ethanol	n/a
Hydrolysis	Fair
Methanol	n/a
Oil	Poor
Oxidation	Excellent
Petrol	Poor
Wear resistance	Good
Weather and ozone	Excellent

### Dimensional drawings

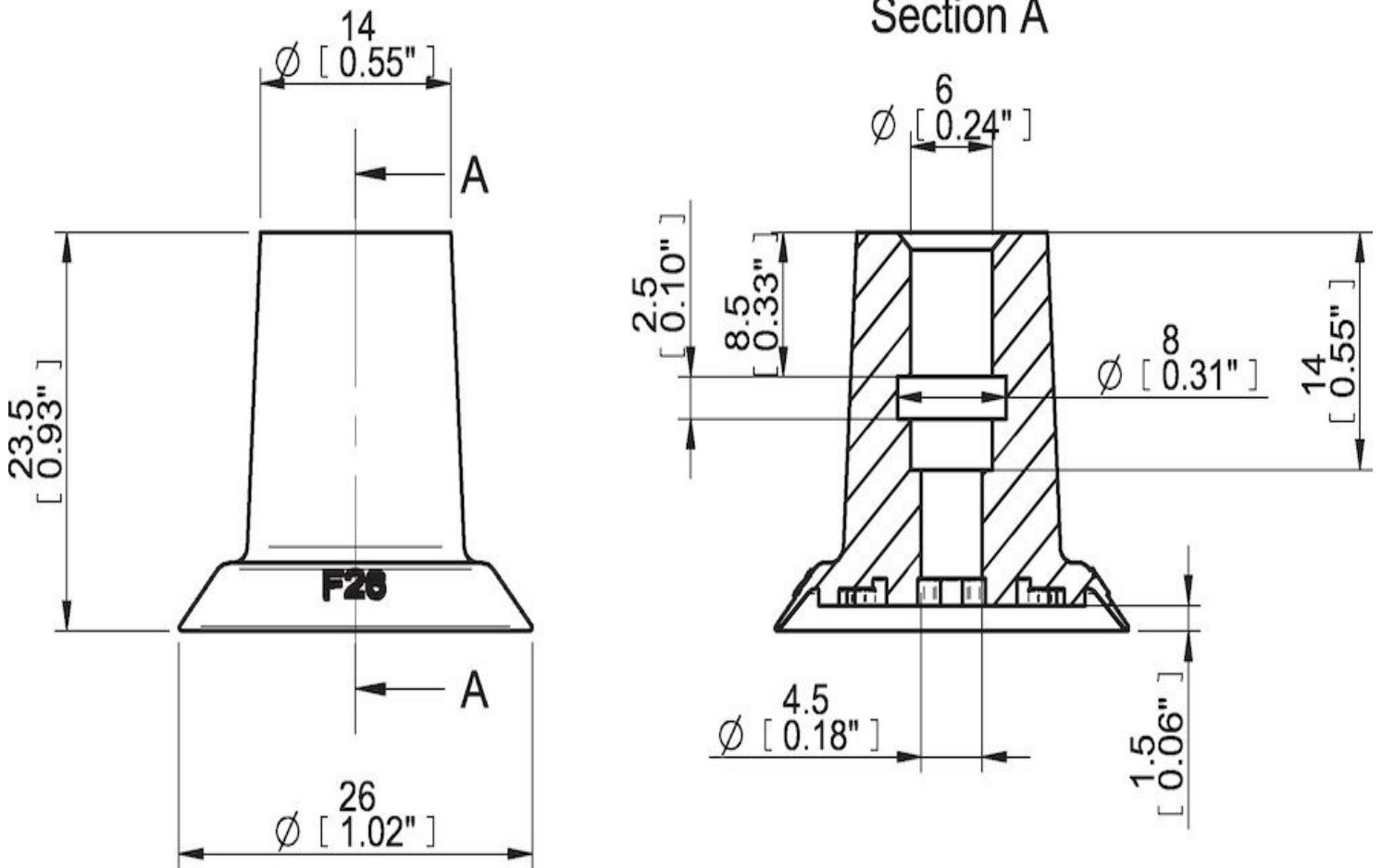

### Values specified in this data sheet are tested at (unless otherwise stated):

- Room temperature (20°C [68°F] ± 3°C [5.5°F]).
- Standard atmosphere (101.3 [29.9 inHg] ± 1.0 kPa [0.3 inHg]).
- Relative humidity 20-70%.
- Compressed air quality, DIN ISO 8573-1 class 4.

### Accessories

0201967 | Fitting G1/4" male  
 0201969 | Fitting 1/8" NPSF female