

## Vacuum Check Valve VT-1H COAX® with level compensator, NPT threads, Ball joint, Right hand connection

Article number: 0121063

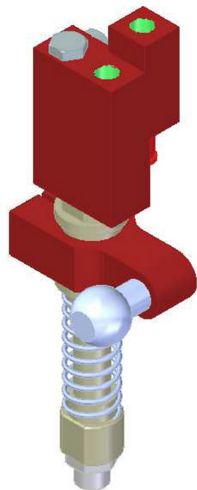

- Two-stage COAX® cartridge MINI Pi12-2 integrated.
- Check valve that traps vacuum in sealed applications for safe operation.
- Built-in blow off check valve for fast release of object.
- Available in lock pin 16, 19 or ball joint mountings, industry standard.
- Available with level compensator to compensate for differences in level of object.
- Recommend using 4mm (5/32") tubing and no more than 80 psi for blow off.
- Recommend using 6mm (1/4") tubing and no more than 80 psi for vacuum.
- Equal line lengths from common manifold should be used for both blow-off and vacuum.
- Maximum of (12) units per tool.

### Technical data

Description	Unit	Value
Material	-	Al, Ceramic, CuZn, Nitrile (NBR), PA, PP, SS, Steel
Load, vertical, max.	N	700
Temperature, max.	°C	80
Temperature, min.	°C	-10
Weight, max.	g	987
Weight, min.	g	943
Feed pressure, max.	MPa	0.55
Feed pressure, min.	MPa	0.25
Noise level, max.	dBA	68
Noise level, min.	dBA	66
Vacuum flow, range, max.	NI/s	0.68
Life span	cycles	10000000
Volume, internal	cm <sup>3</sup>	13.8
Action range	°	0-360
Action range/Stroke	mm	50
Spring force, max.	N	66.7

### Performance

Feed pressure MPa	Air consumption NI/s	Vacuum flow (NI/s) at different vacuum levels (-kPa)													Max vacuum kPa		
		0	10	20	30	40	50	60	70	75	80	90	95	99			
0.17	0.29	0.57	0.4	0.22	0.15	0.07	0	0	0	0	0	0	0	0	0	0	≥49
0.22	0.34	0.64	0.48	0.29	0.2	0.14	0.08	0.02	0	0	0	0	0	0	0	0	≥64
0.314	0.44	0.68	0.6	0.44	0.27	0.19	0.14	0.1	0.06	0	0.03	0	0	0	0	0	≥90
0.4	0.53	0.66	0.6	0.52	0.39	0.24	0.12	0.1	0.06	0	0.02	0	0	0	0	0	≥84

Feed pressure MPa	Air consumption NI/s	Evacuation time (s/l) to reach different vacuum levels (-kPa)													Max vacuum kPa		
		10	20	30	40	50	60	70	80	90	95	99	99.5	100.3			
0.17	0.29	0.28	0.56	1.13	2.13	0	0	0	0	0	0	0	0	0	0	0	≥49
0.22	0.34	0.2	0.42	0.85	1.5	2.3	3	0	0	0	0	0	0	0	0	0	≥64
0.314	0.44	0.17	0.32	0.58	1.1	1.8	2.7	4	6.4	0	0	0	0	0	0	0	≥90
0.4	0.53	0.18	0.33	0.54	0.85	1.5	2.5	3.8	7.1	0	0	0	0	0	0	0	≥84

Feed pressure	Air consumption	Blow flow (Nl/s) at different pressure levels (-kPa)														Max pressure	
MPa	Nl/s	0	10	20	30	40	50	60	70	80	90	100	110	120	130	140	kPa
0.6	0.75	1.37	1.365	1.36	1.345	1.33	1.225	1.12	1.03	1.03	1.03	1.03	1	0.95	0.86	0.79	≥0

## Dimensional drawings

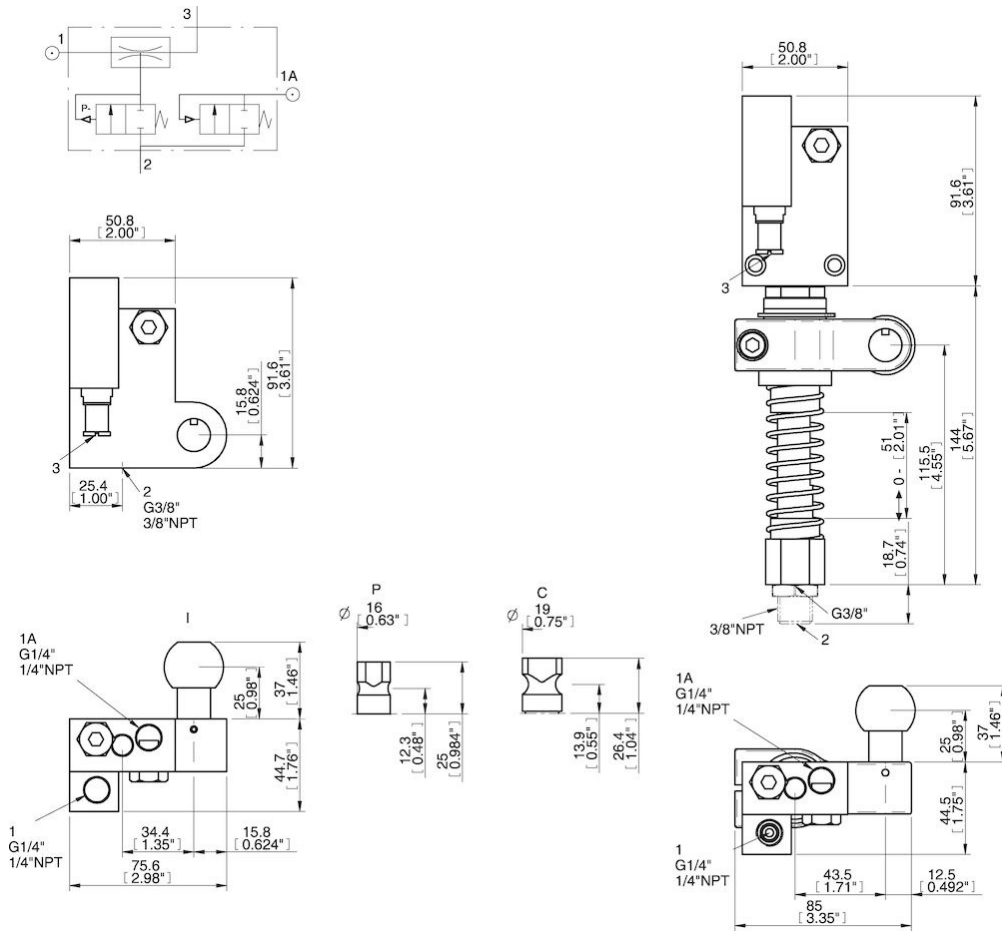

Values specified in this datasheet are tested at (unless otherwise stated):

- Room temperature (20°C [68°F] ± 3°C [5.5°F]).
- Standard atmosphere (101.3 [29.9 inHg] ± 1.0 kPa [0.3 inHg]).
- Compressed air quality, DIN ISO 8573-1 class 4.

Tolerance and accuracy:

- Feed pressure tolerance ±0.02 MPa [2.9 psi]
- Vacuum flow/evacuation time accuracy ±10%.