

piSECURE COAX® Xi10-2 G 1/8"

Article number: 0200986



- Two stage COAX® MINI Xi10-2 ejector gives fast evacuation to 94 -kPa (with ES 65 -kPa)
- Suitable to use as decentralized (one per cup) for maximum safety
- Built-in non-return valve (check valve) which holds vacuum in sealed applications in case of system or power failure
- Suitable for ergonomic lifting devices/manipulators and cranes which has to comply with lifting norms, such as EN 13155 and ASME Standard B30.20 etc.
- Integrated blow-off release valve for fast and reliable release of object
- Filter disc to protect unit from dust and particles
- Vacuum sensing port
- Optional air saving function (piSECURE ES) can save up to 99% of consumption

Technical data

Description	Unit	Value
Material	-	Al, CuZn, Nitrile (NBR), PA, SS
Temperature, max.	°C	80
Temperature, min.	°C	-10
Weight, min.	g	225
Feed pressure, max.	MPa	0.7
Feed pressure, min.	MPa	0.1
Noise level, max.	dB(A)	74
Noise level, min.	dB(A)	65
Feed pressure, optimum, max.	MPa	0.7
Feed pressure, optimum, min.	MPa	0.3
Hysteresis	kPa	8
Signal range, min.	-kPa	65
Flow rate, max.	NI/s	2.8
Flow rate, min. (@ 0.3-0.7 MPa)	NI/s	1.5
Leaking rate, max. (towards a 50 ml volume)	kPa/min	<0,4

Performance

Feed pressure MPa	Air consumption NI/s	Vacuum flow (NI/s) at different vacuum levels (-kPa)													Max vacuum kPa
		0	10	20	30	40	50	60	70	75	80	90	95	99	
0.45	0.42	0.75	0.61	0.45	0.28	0.19	0.15	0.11	0.07	0	0.043	0.003	0	0	≥92
0.5	0.46	0.75	0.63	0.49	0.33	0.19	0.15	0.11	0.07	0	0.045	0.011	0	0	≥94
0.6	0.54	0.74	0.63	0.53	0.42	0.3	0.16	0.11	0.08	0	0.041	0.01	0	0	≥93

Feed pressure MPa	Air consumption NI/s	Evacuation time (s/l) to reach different vacuum levels (-kPa)													Max vacuum kPa
		10	20	30	40	50	60	70	80	90	95	99	99.5	100.3	
0.45	0.42	0.15	0.3	0.6	1.1	1.6	2.3	3.5	5.3	9.6	0	0	0	0	≥92
0.5	0.46	0.14	0.3	0.6	1	1.6	2.3	3.5	5.3	8.9	0	0	0	0	≥94
0.6	0.54	0.15	0.3	0.5	0.8	1.3	2	3.1	4.8	8.7	0	0	0	0	≥93

Dimensional drawings

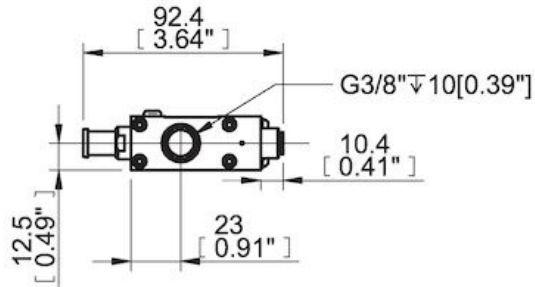
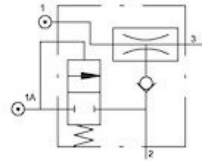
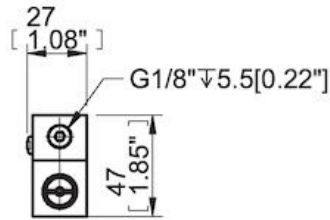
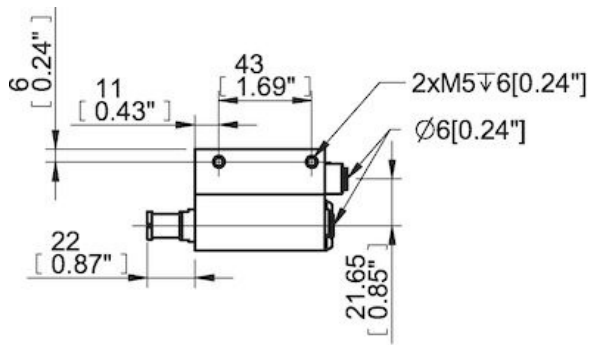

Values specified in this datasheet are tested at (unless otherwise stated):

- Room temperature (20°C [68°F] \pm 3°C [5.5°F]).
- Standard atmosphere (101.3 [29.9 inHg] \pm 1.0 kPa [0.3 inHg]).
- Compressed air quality, DIN ISO 8573-1 class 4.

Tolerance and accuracy:

- Feed pressure tolerance ± 0.02 MPa [2.9 psi]
- Vacuum flow/evacuation time accuracy $\pm 10\%$.

Accessories

0201599 | Swiveling restrictor kit piSECURE