

## COAX® cartridge MICRO Xi2.5-2, holding cap

Article number: 0120283



- Two-stage COAX® cartridge - MICRO - probably the world's smallest multistage vacuum ejector.
- High vacuum flow at deep vacuum levels, to 92 - kPa.
- Large vacuum flow in relation to energy consumption.
- Quick response time when deep vacuum is needed.
- Good for handling sealed materials.

### Technical data

Description	Unit	Value
Material	-	Al, Nitrile (NBR), PA, SS, TPE
Temperature, max.	°C	80
Temperature, min.	°C	-10
Weight, max.	g	2.3
Weight, min.	g	1.5
Feed pressure, max.	MPa	0.7

### Performance

Feed pressure MPa	Air consumption Nl/s	Vacuum flow (Nl/s) at different vacuum levels (-kPa)														Max vacuum kPa
		0	10	20	30	40	50	60	70	80	90	95	99			
0.45	0.12	0.23	0.15	0.075	0.055	0.045	0.034	0.021	0.0092	0	0.003	0	0	0	≥89	
0.5	0.13	0.233	0.15	0.079	0.044	0.036	0.03	0.023	0.013	0	0.007	0	0	0	≥91	
0.6	0.15	0.263	0.19	0.12	0.045	0.035	0.029	0.018	0.01	0	0.003	0	0	0	≥90	

Feed pressure MPa	Air consumption Nl/s	Evacuation time (s/l) to reach different vacuum levels (-kPa)														Max vacuum kPa
		10	20	30	40	50	60	70	80	90	95	99	99.5	100.3		
0.45	0.12	0.54	1.44	2.98	4.98	7.54	11.19	17.8	34.3	0	0	0	0	0	≥89	
0.5	0.13	0.52	1.39	3.01	5.51	8.56	12.32	17.77	27.48	0	0	0	0	0	≥91	
0.6	0.15	0.44	1.08	2.31	4.8	7.93	12.16	19.13	34.22	0	0	0	0	0	≥90	

Feed pressure MPa	Air consumption Nl/s	Blow flow (Nl/s) at different pressure levels (-kPa)														Max pressure kPa	
		0	10	20	30	40	50	60	70	80	90	100	110	120	130		140
0.6	0.15	0.37	0.33	0.26	0.21	0.21	0.2	0.19	0.17	0.15	0	0	0	0	0	0	≥90

## Dimensional drawings

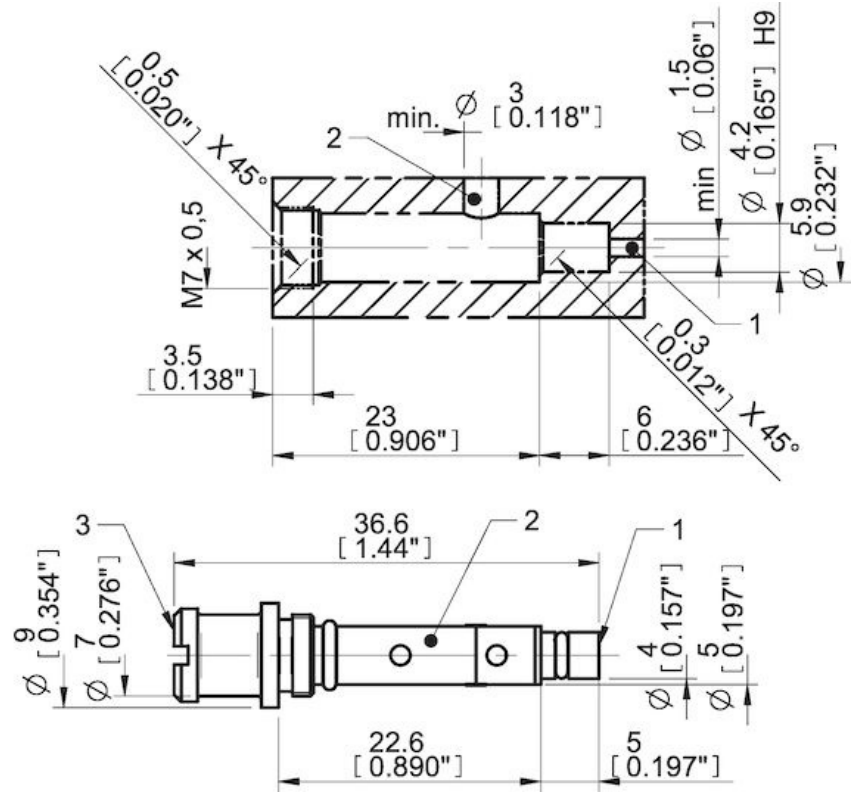
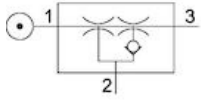

Values specified in this datasheet are tested at (unless otherwise stated):

- Room temperature (20°C [68°F] ± 3°C [5.5°F]).
- Standard atmosphere (101.3 [29.9 inHg] ± 1.0 kPa [0.3 inHg]).
- Compressed air quality, DIN ISO 8573-1 class 4.

Tolerance and accuracy:

- Feed pressure tolerance ±0.02 MPa [2.9 psi]
- Vacuum flow/evacuation time accuracy ±10%.